



ReeTray
200 JUMBO
Semi-Automatic
Tray Sealer









ReeTray 200 JUMBO

Semi-Automatic Tray Sealer

TECHNICAL DATA	DONNÉES TECHNIQUES	ReeTray 200 JUMBO
Overall dimensions	Dimensions Totales	2290 x 1360 x 1870 mm
Height of loading area	Hauteur de la zone de chargement	900 mm
Approx. Weight incl.pump	Poids avec Pompe a Vide	Ca. 500 Kg
Max Tray dimensions, ext.	Dimensions max. des Barquettes	590 x 390 mm
Max Tray depth	Profondeur max. des Barquettes	130 mm
Max width of film sealing	Diamètre max. du rouleau de film	460 mm
Max-diameter of web roll	Largeur max. du film de scellage	250 mm
Diameter of film support shaft	Diametre du moyeu du film	70 - 76 mm
Vacuum pump	Pompe à vide	100 m ³ / h
Electrical supply	Alimentation électrique	3/N/PE 400 V AC - 50 Hz
Power consumption	Consommation	Up to 9,5 KW
Compressed Air	Air comprimé	6 bar - 25 NI / c
Productivity*	Productivité*	Up to 3 cycles / min.

* Productivity may vary depending on operator ability, quality of packaging materials, product to pack, and overall machine configuration. /
La productivité peut varier en fonction de la capacité de l'opérateur, la qualité des matériaux d'emballage, produit à emballer, et la configuration globale de la machine.

NUMBER OF TRAY PROCESSED PER CYCLE ACCORDING TO MAXIMUM TRAY DIMENSIONS / NOMBRE ET DIMENSIONS MAXIMALES DES CONTENANTS TRAITÉS PAR CYCLE.

 <p>FORMAT 1.1</p>	<p>Max. 590 x 390 mm</p> <p>Max. H 130 mm</p>	 <p>FORMAT 3.1</p>	<p>Max. 390 x 190 mm</p> <p>Max. H 130 mm</p>
 <p>FORMAT 1.2</p>	<p>Max. 590 x 180 mm</p> <p>Max. H 130 mm</p>	 <p>FORMAT 3.2</p>	<p>Max. 180 x 190 mm</p> <p>Max. H 130 mm</p>
 <p>FORMAT 2.1</p>	<p>Max. 285 x 390 mm</p> <p>Max. H 130 mm</p>	 <p>FORMAT 4.1</p>	<p>Max. 390 x 135 mm</p> <p>Max. H 130 mm</p>
 <p>FORMAT 2.2</p>	<p>Max. 180 x 285 mm</p> <p>Max. H 130 mm</p>	 <p>FORMAT 4.2</p>	<p>Max. 180 x 135 mm</p> <p>Max. H 130 mm</p>

LAY-OUT ReeTray 200 JUMBO

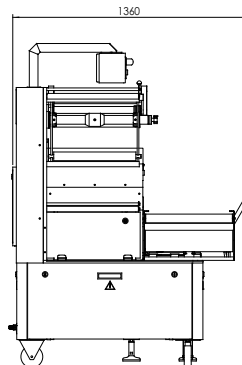
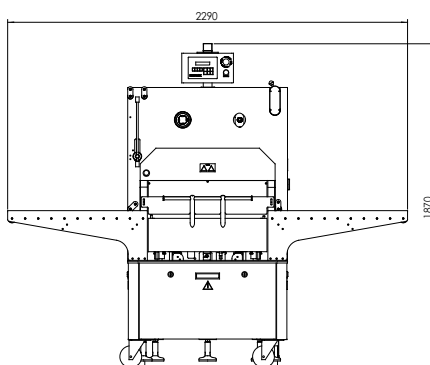

- Control panel positioned for easy operation
- Position du panneau de commande pour une utilisation facile



- Location of air and gas supply
- Placement de l'air et de gaz

Standard: Tray lifting device /
Dispositif de levage Barquette

Due to continuous improvement, designs and specifications are subject to change without notice. / En raison de l'amélioration continue, nous nous réservons le droit d'apporter des modifications aux données présentées sans préavis.

© Copyright By Reepack srl - Rk-PFL-RJ-Rev/000-0117

Reepack S.r.l. Soc.Unip.
I - 24068 Seriate, Bergamo
reepack@reepack.com

Reepack Verpackungsmaschinen GmbH
D - 76297 Stutensee
reepack-de@reepack.com

Reepack Packaging Machinery S.L.
E - 08027 Barcelona
reepack-es@reepack.com

www.reepack.com